

PALLEVOGNE

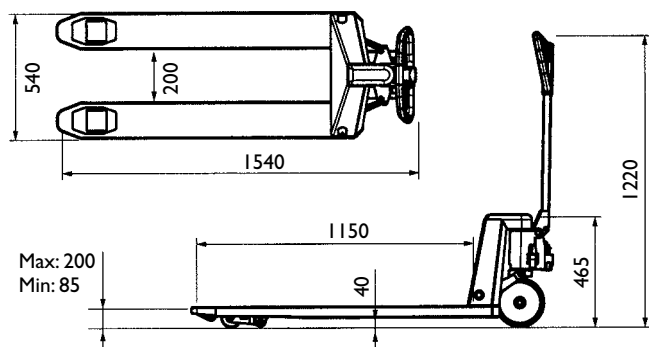

Professionel og manøvreedygtig med quick-lift

- Designet til hårdt, intensivt og professionelt brug
- Ergonomisk og betjeningsvenligt håndtag
- Optimal manøvreedygtighed med drejevinkel på 210°
- Monteret med rulle foran og bagved gaffelhjul for lettere til- og frakørsel på pallens brede side
- Med enkel eller bogie gaffelhjul i nylon eller polyurethan
- Nylonhjul giver en let og ubesværet kørsel
- Polyurethanhjul er støjsvage og skåner underlaget

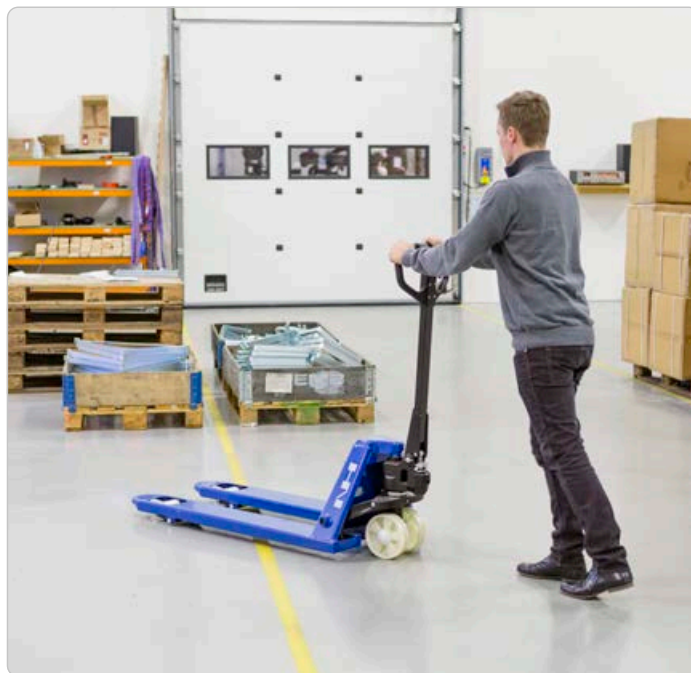

Quick-lift pumpe



Bremse

Varenr.: 8524800



PL2500BNQ



PL2500EPQ



PL2500BPQ



PLM2500EPQ

Model		PLM2500ENQ	PLM2500BNQ	PLM2500EPQ	PLM2500BPQ
Løftekapacitet	kg	2500	2500	2500	2500
Gaffellængde	mm	1150	1150	1150	1150
Gaffelbredde	mm	540	540	540	540
Drejevinkel		210°	210°	210°	210°
Hjultype		Nylon	Nylon	Polyurethan	Polyurethan
Hjulmontering		Enkel	Bogie	Enkel	Bogie
Vægt	kg	70	70	70	70
Varenr.		7930156	7930456	7930656	7930556